

# ROLLER STAND (HEAVY DUTY)

*Floor or bench mountable pipe trestles*

These heavy duty stands are designed to be either floor or bench mounted. Available with 4 adjustable head styles to suit pipes from 4 - 48" / 100 - 1,220 mm.

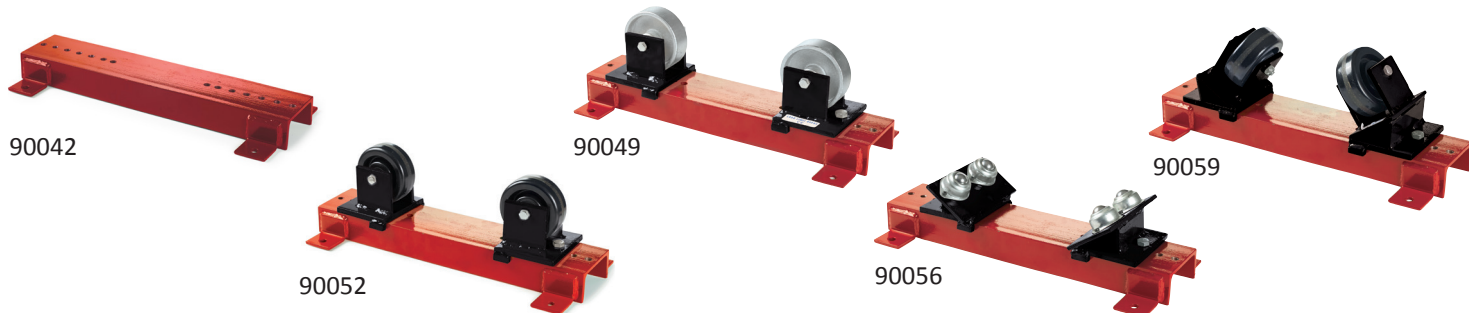

The above part numbers are for wheel heads only. Base (90042) not included.

OLD PART NO	NEW PART NO	DESCRIPTION	WEIGHT CAPACITY		PIPE DIAMETER CAPACITY		UNIT WEIGHT	
RPS500	90042	Base unit only	5,290 lbs.	2,400 kg	4" - 48"	100 - 1,220 mm	13 lbs.	5.80 kg
SWH500	90049	Steel wheel heads (pair)	5,290 lbs.	2,400 kg	4" - 48"	100 - 1,220 mm	8 lbs.	3.50 kg
* SWH500SS	* 90050	Stainless steel wheel heads (pair)	5,290 lbs.	2,400 kg	4" - 48"	100 - 1,220 mm	8 lbs.	3.50 kg
* NWH500	* 90052	Phenolic wheel heads (pair)	1,000 lbs.	450 kg	4" - 48"	100 - 1,220 mm	5 lbs.	2.20 kg
* BTH500SS	* 90056	Stainless steel ball transfer heads (pair)	1,000 lbs.	450 kg	4" - 48"	100 - 1,220 mm	8 lbs.	3.50 kg
S/FTR500	90057	Steel feed through roller (pair)	5,290 lbs.	2,400 kg	4" - 48"	100 - 1,220 mm	8 lbs.	3.50 kg
* SS/FTR500	* 90058	Stainless steel feed through roller (pair)	5,290 lbs.	2,400 kg	4" - 48"	100 - 1,220 mm	8 lbs.	3.50 kg
* N/FTR500	* 90059	Nylon feed through roller head (pair)	1,000 lbs.	450 kg	4" - 48"	100 - 1,220 mm	7 lbs.	3.00 kg

*\* Suitable for stainless steel*