

# MEGA ROLLER STAND - 15,000 lbs. 7.5 US TON

The B&B mega roller (15,000 lbs. / 6,803 kg) is a high capacity pipe roller designed for heavy duty job-site use. This mega roller is built on the same platform as the 10,000 lbs. roller, but has an increased headstock width and two additional wheels added.

Its oversized 10" x 3" wheels have an urethane over steel design, offering numerous advantages: they allow ultra smooth pipe rotation via heavy duty sealed bearings, for both steel, stainless steel and exotic alloys pipe. The unique head design also allows the removal of the wheels, transforming to a V-head stand restricting pipe rotation.

The robust construction, with its twin solid ACME rods, allows to raise and lower the headstock and wheels for precise fit-ups even under load.

All mega rollers are powder coated, have quick release axle pins, and are modular allowing additional feed wheels and casters for mega movement.

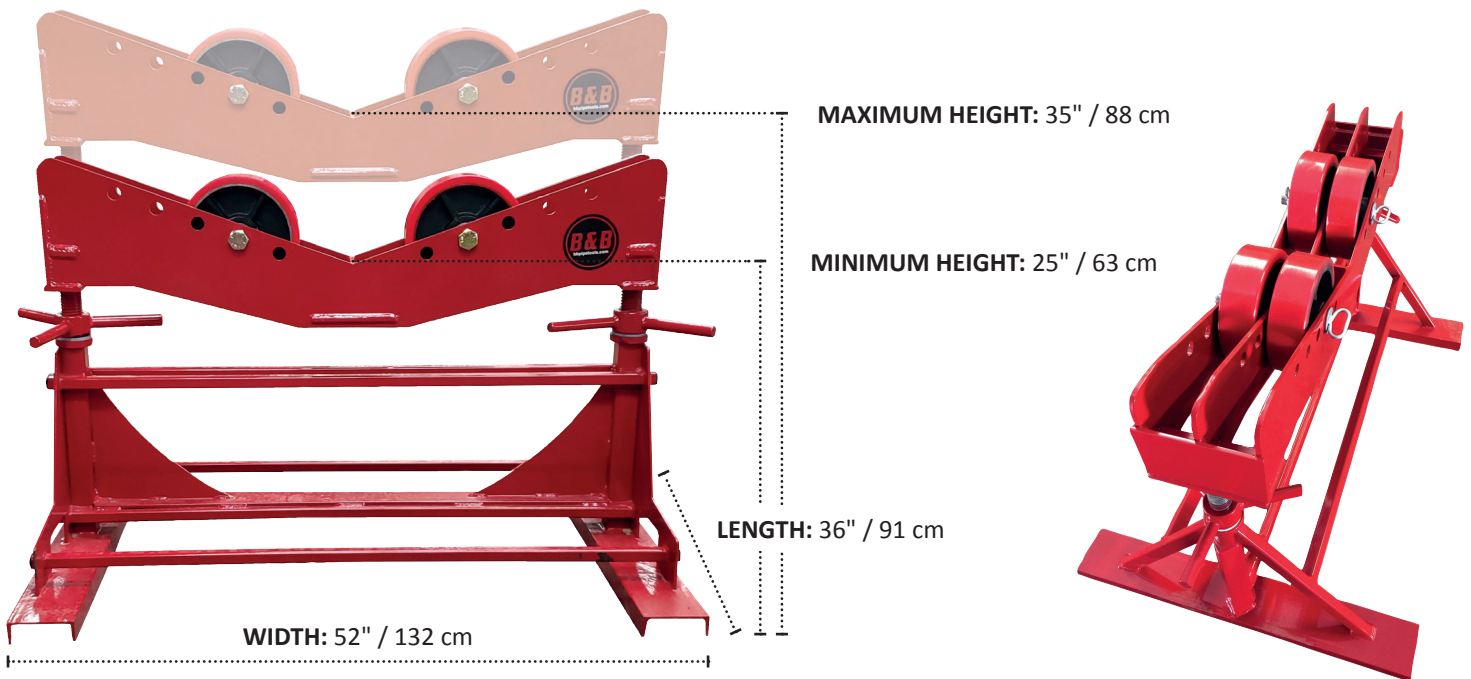

## Specifications

- Weight capacity: 15,000 lbs. / 6,803 kg
- Pipe capacity: 4" - 60" / 10 - 152 cm
- Working height: 25" - 35" / 63 - 88 cm
- Four 10" x 3" heavy duty urethane over steel wheels with sealed bearings for smooth pipe rotation.
- Contamination free wheels are ideal for steel and exotic pipe fabrication.
- Heavy gauge steel construction throughout. These mega rollers are made for years of job-site abuse.
- Powder coated safety red for high visibility.
- Expanded foot print at 36" x 52" / 91 x 132 cm increases pipe stability.
- Modular design allows caster and feed roller additions.
- Four side fork lift access.

OLD PART NO	NEW PART NO	DESCRIPTION	WEIGHT CAPACITY		PIPE DIAMETER CAPACITY		UNIT WEIGHT		FOOTPRINT		STANDARD HEIGHT ADJUSTMENT	
			lbs.	kg	in	cm	lbs.	kg	in	cm	in	cm
MPS8000	3808	Mega Roller - 15,000 lbs.	15,000	6,803	4" - 60"	10 - 152	350	158.7	36" x 52"	91 x 132	25" - 35"	63.5 - 89